

## ENGINE

Model	Isuzu AQ-4HK1X
Emissions Certification	Tier 4 Final
Fuel	Requires ultra-low sulfur fuel B5 biodiesel tolerant
Type	Water-cooled, 4-cycle diesel, high pressure common rail system – electric control. VGT Turbocharger w/ air cooled intercooler, SCR system
Cylinders	4-cylinder in-line
Displacement	317 in <sup>3</sup> (5.2 L)
Bore/Stroke	4.53 x 4.92 in (115 x 125 mm)
Fuel injection	Direct injection – electronic
Fuel filter	Replaceable, full flow spin-on cartridge
Air filter	Dry type element w/ warning restriction indicator
Oil filter	Replaceable, full flow spin-on cartridge
Engine gradeability:	
Side-to-side	35°
Fore and aft	35°
Net horsepower – SAE J1349 @ 2000 RPM:	177 hp (132.1 kW)
Net max. torque – SAE J1349 @ 1800 RPM:	458 lbf-ft (621 N·m)
Cooling operating range:	113° to -4°F (45° to -20°C)
Oil	Requires low-ash oil CJ-4

## DRIVETRAIN

Travel control	Dual stage relief/ counter balance design
Brakes	Mechanical disc
Service brakes	SAHR disc – each motor
Two speed travel:	
Max. high speed	3.4 mph (5.5 km/h)
Max. low speed	2.2 mph (3.2 km/h)
Automatic downshift	3.5
Drawbar pull	44,962 lbf (200 kN)
Gradeability	70% – 35° Slope

## ELECTRICAL

Voltage	24 Volts
Alternator rating	50 amp
Batteries	2 x 12 Volt
Battery reserve capacity	92 Ah/5 hour
Work lights – 4	24 Volt/70 watt
1 boom, 1 upper, 2 cab	

## OPERATOR ENVIRONMENT

Air conditioner output	18,100 BTU/hr
Heater output	20,150 BTU/hr
Sound level inside cab – ISO6396	70 dBA
Electrical outlet	12 Volt
Cab interior light	10 watt
Rear view camera	Standard
Seat	Air-suspension, heated and 65° tiltable

### Monitor:

Rear view and side view – optional camera display; Mode 1: work mode; Travel mode; Attachment selection; Auto idle indicator; Fuel consumption gauge; Power boost icon; Fuel bar graph; Oil temperature bar graph; DEF/AdBlue bar graph; Auto glow indicator; Auxiliary mode display; Hour meter; Camera angle indicator; Mode 2: free swing/swing lock indicator; Light icon; Wiper icon; Mute icon; Seat belt icon; Warning messages; Time and date; Water temperature bar graph; DEF/AdBlue refill icon; Anti-theft icon; DTC indicator; Low output icon; SCR cleaning icon; SCR warning icons; Freeze protection; Trip meter; Pressure reading.

### Seat:

High-back seat w/ heat and air suspension; Adjustments: 65° tilt, manual weight, seat height, headrest, lumbar support, backrest angle, pivoting armrests linked to consoles; Retractable seat belt and control consoles adjust independently of seat.

## ATTACHMENT

Boom	19 ft 2 in (5.85 m)
Arm options:	
Standard	9 ft 10 in (3.00 m)
Short	8 ft 2 in (2.50 m)
Long	11 ft 6 in (3.52 m)
Bucket digging force*	36,419 lbf (162 kN)
w/ Auto Power-Boost	39,566 lbf (176 kN)

NOTE: \*Digging force ratings based on ISO6015.

## OPERATING WEIGHT

Operating weight	56,909 lb (25 814 kg)
w/ shoes	2 ft 7 in (800 mm)
w/ boom	19 ft 2 in (5.85 m)
w/ arm	9 ft 10 in (3.00 m)
w/ bucket	1,786 lb (810 kg)
w/ counterweight	11,508 lb (5 220 kg)

NOTE: W/ operator/full fuel/standard equipment.

## GROUND PRESSURE

@ Standard operating weight 5.5 psi (0.38 bar)  
w/ 31.5 in (800 mm) triple semi-grouser shoes

## HYDRAULICS

System design	Open center
Main pumps	Two-variable displacement/ axial piston
Max. rated flow	61.8 gpm (234 L/min)
System pressures:	
Boom, arm and bucket w/ Power Boost	4,975 psi (343 bar) 5,410 psi (373 bar)
Travel circuits	4,975 psi (343 bar)
Swing circuits	4,192 psi (289 bar)
Pilot pump	1 x gear design
Max. capacity	5.3 gpm (20 L/min)
Controls	w/ boom/arm holding valve
Right track travel, bucket, boom and arm acceleration.	1 x Four-spool section
Left track travel, bucket, boom and arm acceleration.	1 x Five-spool section
Work mode selections	SP: Speed Priority H: Heavy-Duty A: Automatic
Swing motor	Fixed displacement axial piston
Swing final drive	Planetary gear reduction
Travel motor	Two-speed independent travel/axial piston

## HYDRAULIC CYLINDERS

Boom cylinders	Two (2)
Cylinder bore	5.1 in (130 mm)
Cylinder rod diameter	3.5 in (90 mm)
Cylinder stroke	52.6 in (1 335 mm)
Arm cylinder	One (1)
Cylinder bore	5.7 in (145 mm)
Cylinder rod diameter	4.1 in (105 mm)
Cylinder stroke	65.4 in (1 660 mm)
Bucket cylinder	One (1)
Cylinder bore	5.1 in (130 mm)
Cylinder rod diameter	3.5 in (90 mm)
Cylinder stroke	42.1 in (1 070 mm)

## SERVICE CAPACITIES

Fuel tank	108.3 gal (410 L)
Hydraulic system	66.0 gal (250 L)
Hydraulic tank	38.8 gal (147 L)
Engine oil w/ filter	6.1 gal (23.1 L)
Swing drive	2.6 gal (9.7 L)
Final drive	1.3 gal (5 L)
Cooling system	8.3 gal (31.4 L)
DEF Tank	31.7 gal (120 L)

## OTHER SPECIFICATIONS

Swing speed	10.6 RPM
Swing torque	55,243 lb-ft (74.9 kN-m)
Swing brake	Mechanical disc
Undercarriage:	
Length	15 ft 3 in (4 650 mm)
Track gauge	8 ft 6 in (2 590 mm)
Carrier rollers	2
Track rollers	9
Shoes – triple grouser	
Shoe width – std.	2 ft 7 in (800 mm)
Link pitch	7.5 in (190 mm)
Track:	
Chain	Grease lubricated/strutted
Guides	Single
Adjustment	Hydraulic

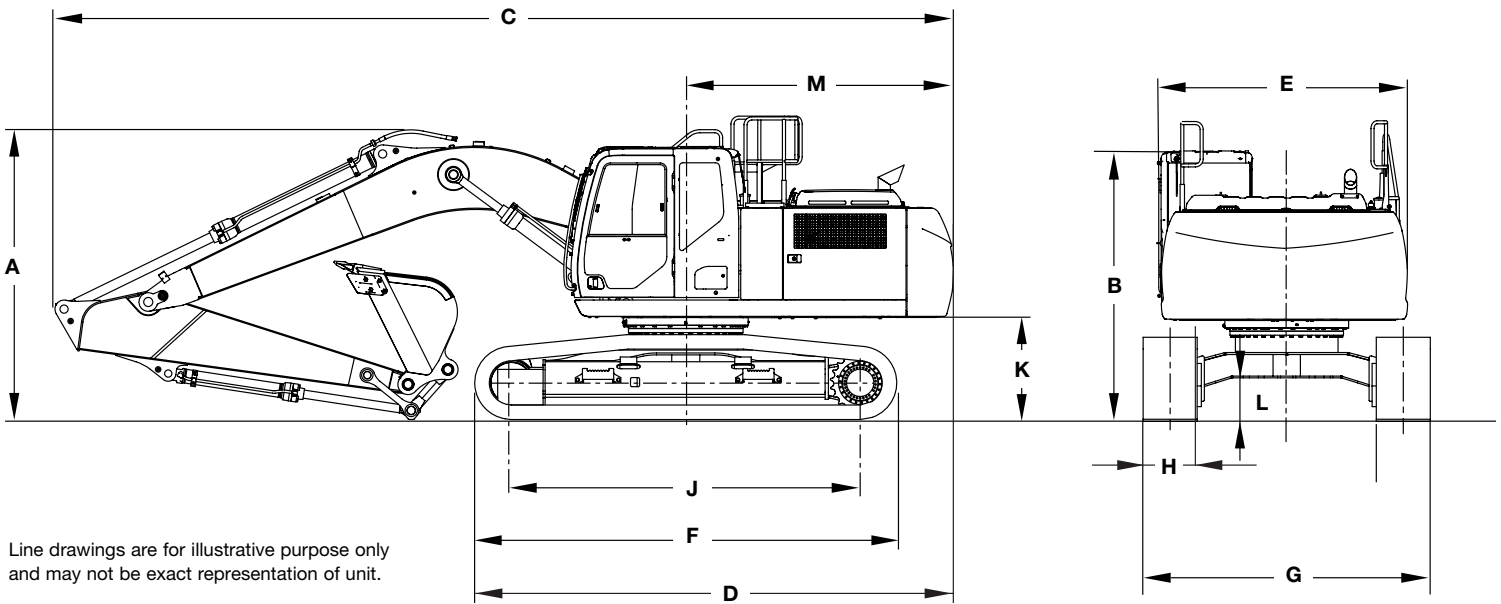

Line drawings are for illustrative purpose only and may not be exact representation of unit.

## DIMENSIONS

	9 ft 10 in (3.0 m) Arm	8 ft 2 in (2.5 m) Arm	11 ft 6 in (3.52 m) Arm
<b>A.</b> Overall height – with attachment	10 ft 6 in (3 200 mm)	11 ft 0 in (3 350 mm)	11 ft 0 in (3 360 mm)
<b>B.</b> Cab height	10 ft 0 in (3 050 mm)	10 ft 0 in (3 050 mm)	10 ft 0 in (3 050 mm)
Overall height to top of guardrail	10 ft 11 in (3 340 mm)	10 ft 11 in (3 340 mm)	10 ft 11 in (3 340 mm)
<b>C.</b> Overall length – with attachment	32 ft 5 in (9 880 mm)	32 ft 8 in (9 950 mm)	32 ft 6 in (9 910 mm)
<b>D.</b> Overall length – without attachment	17 ft 3 in (5 270 mm)	17 ft 3 in (5 270 mm)	17 ft 3 in (5 270 mm)
<b>E.</b> Width of upper structure	9 ft 1 in (2 770 mm)	9 ft 1 in (2 770 mm)	9 ft 1 in (2 770 mm)
<b>F.</b> Track overall length	15 ft 3 in (4 650 mm)	15 ft 3 in (4 650 mm)	15 ft 3 in (4 650 mm)
<b>G.</b> Track overall width with 31.5 in (800 mm) shoes	11 ft 1 in (3 390 mm)	11 ft 1 in (3 390 mm)	11 ft 1 in (3 390 mm)
<b>H.</b> Track shoe width	2 ft 7 in (800 mm)	2 ft 7 in (800 mm)	2 ft 7 in (800 mm)
<b>J.</b> Center to center – idler to sprocket	12 ft 7 in (3 840 mm)	12 ft 7 in (3 840 mm)	12 ft 7 in (3 840 mm)
<b>K.</b> Upper structure ground clearance	3 ft 7 in (1 100 mm)	3 ft 7 in (1 100 mm)	3 ft 7 in (1 100 mm)
<b>L.</b> Minimum ground clearance	1 ft 5 in (440 mm)	1 ft 5 in (440 mm)	1 ft 5 in (440 mm)
<b>M.</b> Rear tail swing radius	9 ft 8 in (2 950 mm)	9 ft 8 in (2 950 mm)	9 ft 8 in (2 950 mm)
Operating weight*	56,909 lb (25 814 kg)	56,358 lb (25 564 kg)	57,240 lb (25 964 kg)
Ground pressure	5.5 psi (0.38 bar)	5.5 psi (0.38 bar)	5.5 psi (0.38 bar)

NOTE: \*With 19 ft 2 in (5.85 m) boom, 31.5 in (800 mm) track shoe, 1,786 lb (810 kg) bucket, 165 lb (75 kg) operator, full fuel and standard equipment.

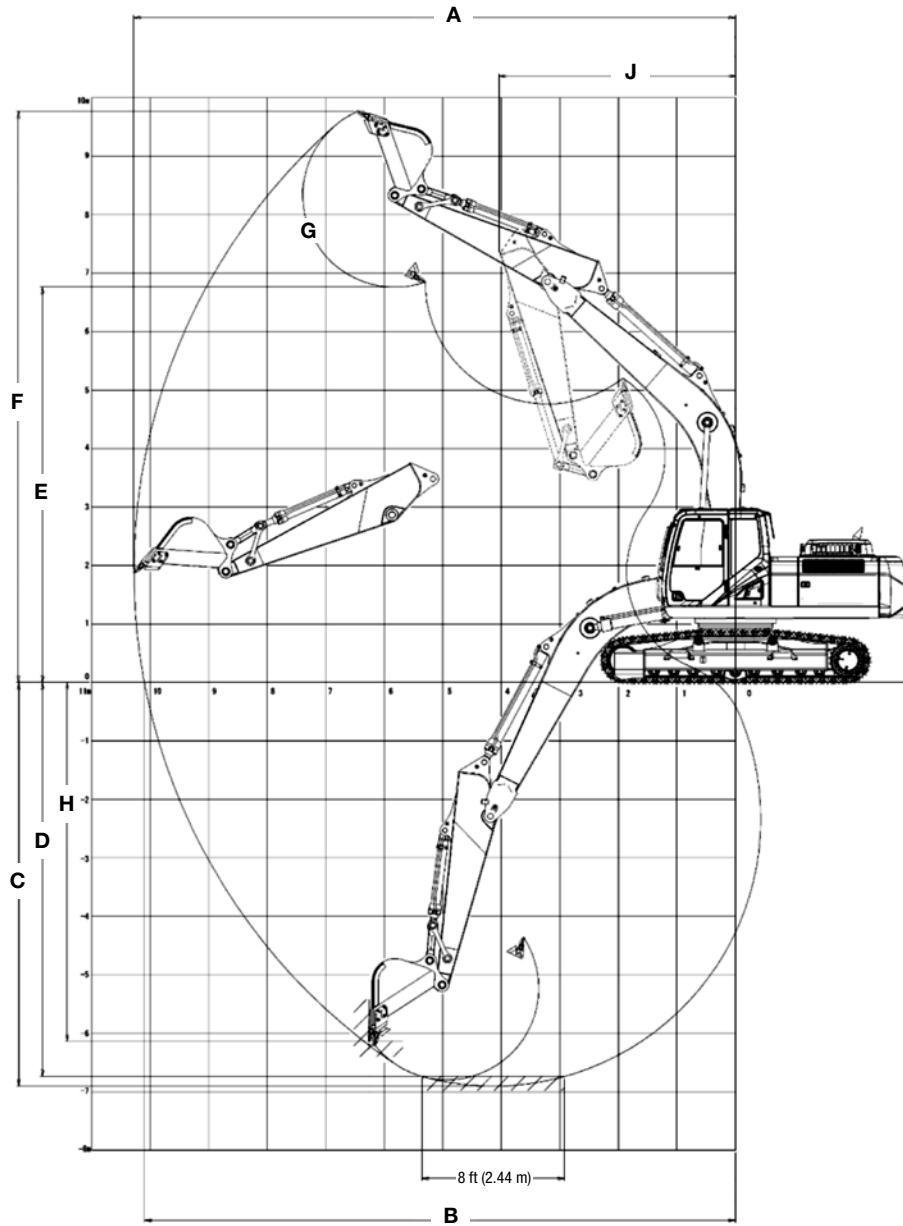

**PERFORMANCE SPECS**

	<b>9 ft 10 in (3.0 m) Arm</b>	<b>8 ft 2 in (2.5 m) Arm</b>	<b>11 ft 6 in (3.52 m) Arm</b>
<b>A.</b> Maximum dig radius	33 ft 9 in (10 280 mm)	32 ft 3 in (9 820 mm)	35 ft 5 in (10 790 mm)
<b>B.</b> Dig radius at groundline	33 ft 2 in (10 100 mm)	31 ft 7 in (9 630 mm)	34 ft 10 in (10 620 mm)
<b>C.</b> Maximum dig depth	22 ft 8 in (6 900 mm)	21 ft 0 in (6 400 mm)	24 ft 4 in (7 420 mm)
<b>D.</b> Dig depth – 8 ft 0 in (2.44 m) level bottom	22 ft 1 in (6 740 mm)	20 ft 4 in (6 210 mm)	23 ft 10 in (7 270 mm)
<b>E.</b> Dump height	22 ft 2 in (6 760 mm)	21 ft 6 in (6 550 mm)	23 ft 2 in (7 060 mm)
<b>F.</b> Maximum reach height	32 ft 0 in (9 760 mm)	31 ft 4 in (9 560 mm)	33 ft 0 in (10 070 mm)
<b>G.</b> Bucket rotation	175°	175°	175°
<b>H.</b> Maximum vertical wall dig depth	20 ft 2 in (6 140 mm)	18 ft 8 in (5 700 mm)	21 ft 11 in (6 680 mm)
<b>J.</b> Minimum swing radius	13 ft 3 in (4 030 mm)	13 ft 1 in (3 980 mm)	13 ft 3 in (4 050 mm)
Arm digging force:			
Standard	26,977 lbf (120 kN)	31,698 lbf (141 kN)	24,055 lbf (107 kN)
Power Boost	29,225 lbf (130 kN)	34,396 lbf (153 kN)	26,078 lbf (116 kN)
Bucket digging force:			
Standard	36,419 lbf (162 kN)	36,419 lbf (162 kN)	36,419 lbf (162 kN)
Power Boost	39,566 lbf (176 kN)	39,566 lbf (176 kN)	39,566 lbf (176 kN)

# LIFT CAPACITIES

**9 ft 10 in (3.0 m)** Lift capacities using a 1,786 lb (810 kg) bucket, 11,508 lb (5 220 kg) counterweight.

Load (Lift Point Height)	5 ft (1.5 m)		10 ft (3 m)		15 ft (4.5 m)		20 ft (6 m)		25 ft (7.5 m)		30 ft (9 m)		MAXIMUM REACH			
	END	SIDE	END	SIDE	END	SIDE	END	SIDE	END	SIDE	END	SIDE	@	END	SIDE	
+25 ft (7.5 m)										8,700 lb* (4 230 kg)*	8,700 lb* (4 230 kg)*			26 ft 8 in (8.23 m)	5,400 lb* (2 430 kg)*	5,400 lb* (2 430 kg)*
+20 ft (6 m)										10,700 lb* (4 900 kg)*	10,300 lb (4 810 kg)	(2 900 kg)*	(2 900 kg)*	29 ft 9 in (9.12 m)	5,100 lb* (2 310 kg)*	5,100 lb* (2 310 kg)*
+15 ft (4.5 m)							13,600 lb* (6 300 kg)*	13,600 lb* (6 300 kg)*	12,450 lb* (5 760 kg)*	10,000 lb (4 670 kg)	9,250 lb* (4 560 kg)*	7,150 lb (3 350 kg)	31 ft 7 in (9.66 m)	5,050 lb* (2 290 kg)*	5,050 lb* (2 290 kg)*	
+10 ft (3 m)			29,200 lb* (13 660 kg)*	29,200 lb* (13 660 kg)*	21,250 lb* (9 880 kg)*	21,250 lb* (9 880 kg)*	16,400 lb* (7 590 kg)*	13,900 lb (6 460 kg)	13,900 lb* (6 400 kg)*	9,600 lb (4 470 kg)	10,500 lb (4 900 kg)	7,000 lb (3 260 kg)	32 ft 6 in (9.9 m)	5,200 lb* (2 360 kg)*	5,200 lb* (2 360 kg)*	
+5 ft (1.5 m)			22,500 lb* (9 550 kg)*	22,500 lb* (9 550 kg)*	26,350 lb* (12 230 kg)*	20,500 lb (9 510 kg)	19,050 lb* (8 810 kg)*	13,100 lb (6 090 kg)	13,900 lb (6 460 kg)	9,200 lb (4 280 kg)	10,300 lb (4 790 kg)	6,750 lb (3 150 kg)	32 ft 5 in (9.89 m)	5,500 lb* (2 490 kg)*	5,500 lb* (2 490 kg)*	
Groundline			21,350 lb* (9 400 kg)*	21,350 lb* (9 400 kg)*	29,200 lb* (13 500 kg)*	19,350 lb (8 990 kg)	19,350 lb (9 000 kg)	12,500 lb (5 810 kg)	13,500 lb (6 290 kg)	8,850 lb (4 120 kg)	10,100 lb (4 700 kg)	6,600 lb (3 070 kg)	31 ft 7 in (9.64 m)	6,000 lb* (2 730 kg)*	6,000 lb* (2 730 kg)*	
-5 ft (-1.5 m)	20,150 lb* (9 040 kg)*	20,150 lb* (9 040 kg)*	27,050 lb* (12 000 kg)*	27,050 lb* (12 000 kg)*	29,650 lb* (13 700 kg)*	19,000 lb (8 830 kg)	18,950 lb (8 820 kg)	12,150 lb (5 660 kg)	13,300 lb (6 190 kg)	8,650 lb (4 030 kg)	(4 250 kg)*	(3 060 kg)	29 ft 11 in (9.13 m)	6,950 lb* (3 140 kg)*	6,600 lb (2 990 kg)	
-10 ft (-3 m)	24,850 lb* (11 130 kg)*	24,850 lb* (11 130 kg)*	36,500 lb* (16 120 kg)*	36,500 lb* (16 120 kg)*	28,850 lb* (13 330 kg)*	19,100 lb (8 890 kg)	19,000 lb (8 840 kg)	12,250 lb (5 690 kg)	13,450 lb (6 250 kg)	8,850 lb (4 090 kg)			27 ft 3 in (8.34 m)	8,550 lb* (3 850 kg)*	7,700 lb (3 460 kg)	
-15 ft (-4.5 m)	34,550 lb* (15 350 kg)*	34,550 lb* (15 350 kg)*	37,300 lb* (17 320 kg)*	37,300 lb* (17 320 kg)*	25,750 lb* (11 970 kg)*	19,600 lb (9 110 kg)	18,650 lb* (8 720 kg)*	12,750 lb (5 890 kg)					23 ft 4 in (7.18 m)	12,000 lb* (5 300 kg)*	9,950 lb (4 430 kg)	
-20 ft (-6 m)			26,200 lb (12 480 kg)*	26,200 lb (12 480 kg)*	17,800 lb (8 590 kg)*	17,800 lb (8 590 kg)*							17 ft 2 in (5.44 m)	14,050 lb* (6 150 kg)*	14,050 lb* (6 150 kg)*	

**8 ft 2 in (2.5 m)** Lift capacities using a 1,918 lb (870 kg) bucket, 11,508 lb (5 220 kg) counterweight.

Load (Lift Point Height)	5 ft (1.5 m)		10 ft (3 m)		15 ft (4.5 m)		20 ft (6 m)		25 ft (7.5 m)		30 ft (9 m)		MAXIMUM REACH		
	END	SIDE	END	SIDE	END	SIDE	END	SIDE	END	SIDE	END	SIDE	@	END	SIDE
+25 ft (7.5 m)									(4 220 kg)*	(4 220 kg)*			24 ft 9 in (7.64 m)	7,800 lb* (3 510 kg)*	7,800 lb* (3 510 kg)*
+20 ft (6 m)							13,050 lb*	13,050 lb*	11,800 lb* (5 440 kg)*	10,050 lb (4 690 kg)			28 ft 1 in (8.61 m)	7,400 lb* (3 340 kg)*	7,400 lb* (3 340 kg)*
+15 ft (4.5 m)					12,850 lb* (6 360 kg)*	12,850 lb* (6 360 kg)*	14,700 lb* (6 780 kg)*	14,150 lb (6 570 kg)	13,300 lb* (6 140 kg)*	9,800 lb (4 550 kg)	7,550 lb* (4 440 kg)*	6,950 lb (3 250 kg)	30 ft 1 in (9.18 m)	7,300 lb* (3 310 kg)*	6,900 lb (3 120 kg)
+10 ft (3 m)			33,300 lb* (12 750 kg)*	33,300 lb* (12 750 kg)*	22,400 lb* (10 300 kg)*	21,350 lb (9 920 kg)	17,300 lb* (8 000 kg)*	13,600 lb (6 310 kg)	14,050 lb (6 530 kg)	9,400 lb (4 730 kg)	10,350 lb (4 820 kg)	6,800 lb (3 180 kg)	30 ft 11 in (9.44 m)	7,500 lb* (3 390 kg)*	6,400 lb (2 900 kg)
+5 ft (1.5 m)					26,750 lb* (12 330 kg)*	19,950 lb (9 270 kg)	19,550 lb (9 090 kg)	12,850 lb (5 970 kg)	13,700 lb (6 380 kg)	9,000 lb (4 190 kg)	10,150 lb (4 730 kg)	6,650 lb (3 090 kg)	30 ft 11 in (9.42 m)	7,900 lb* (3 580 kg)*	6,300 lb (2 850 kg)
Groundline			19,600 lb* (8 640 kg)*	19,600 lb* (8 640 kg)*	29,600 lb* (13 670 kg)*	19,050 lb (8 860 kg)	19,100 lb (8 900 kg)	12,300 lb (5 720 kg)	13,400 lb (6 220 kg)	8,700 lb (4 060 kg)	8,950 lb* (4 670 kg)	6,550 lb (3 040 kg)	30 ft 1 in (9.16 m)	8,600 lb* (3 900 kg)*	6,500 lb (2 950 kg)
-5 ft (-1.5 m)	22,000 lb* (9 810 kg)*	22,000 lb* (9 810 kg)*	27,750 lb* (12 270 kg)*	27,750 lb* (12 270 kg)*	29,450 lb* (13 600 kg)*	18,950 lb (8 810 kg)	18,900 lb (8 790 kg)	12,100 lb (5 620 kg)	13,300 lb (6 170 kg)	8,650 lb (4 010 kg)			28 ft 3 in (8.63 m)	9,950 lb* (4 490 kg)*	7,200 lb (3 250 kg)
-10 ft (-3 m)	27,550 lb* (12 310 kg)*	27,550 lb* (12 310 kg)*	40,300 lb* (17 740 kg)*	37,850 lb (17 610 kg)	28,050 lb* (12 960 kg)*	19,200 lb (8 920 kg)	19,050 lb (8 850 kg)	12,300 lb (5 700 kg)	13,500 lb (6 290 kg)	8,850 lb (4 140 kg)			25 ft 5 in (7.79 m)	12,400 lb* (5 540 kg)*	8,550 lb (3 850 kg)
-15 ft (-4.5 m)	(17 740 kg)*	(17 740 kg)*	33,950 lb* (15 780 kg)*	33,950 lb* (15 780 kg)*	23,850 lb* (11 120 kg)*	19,850 lb (9 210 kg)	16,700 lb* (7 920 kg)*	12,850 lb (5 970 kg)*					21 ft 2 in (6.53 m)	14,500 lb* (6 570 kg)*	11,550 lb (5 130 kg)

NOTE: \*Following number indicates hydraulic capacity.

# LIFT CAPACITIES

**11 ft 6 in (3.5 m)** Lift capacities using a 1,742 lb (790 kg) bucket, 11,508 lb (5 220 kg) counterweight.

Load (Lift Point Height)	5 ft (1.5 m)		10 ft (3 m)		15 ft (4.5 m)		20 ft (6 m)		25 ft (7.5 m)		30 ft (9 m)		MAXIMUM REACH			
	END	SIDE	END	SIDE	END	SIDE	END	SIDE	END	SIDE	END	SIDE	@	END	SIDE	
										(2 300 kg)*	(2 300 kg)*			(7.57 m)	(2 180 kg)*	(2 180 kg)*
<b>+25 ft (7.5 m)</b>										7,350 lb* (3 380 kg)*	7,350 lb* (3 380 kg)*			28 ft 9 in (8.85 m)	4,300 lb* (1 950 kg)*	4,300 lb* (1 950 kg)*
<b>+20 ft (6 m)</b>										9,500 lb* (4 430 kg)*	9,500 lb* (4 430 kg)*	7,200 lb* (3 570 kg)*	7,200 lb* (3 460 kg)	31 ft 7 in (9.68 m)	4,100 lb* (1 850 kg)*	4,100 lb* (1 850 kg)*
<b>+15 ft (4.5 m)</b>										11,550 lb* (5 280 kg)*	10,150 lb (4 730 kg)	9,300 lb* (4 390 kg)*	7,250 lb (3 390 kg)	33 ft 4 in (10.18 m)	4,050 lb* (1 830 kg)*	4,050 lb* (1 830 kg)*
<b>+10 ft (3 m)</b>					19,200 lb* (8 920 kg)*	19,200 lb* (8 920 kg)*	15,250 lb* (7 040 kg)*	14,050 lb (6 520 kg)	13,000 lb* (5 990 kg)*	9,700 lb (4 520 kg)	10,550 lb (4 930 kg)*	7,000 lb (3 270 kg)	34 ft 2 in (10.41 m)	4,100 lb* (1 880 kg)*	4,100 lb* (1 880 kg)*	
<b>+5 ft (1.5 m)</b>			32,550 lb* (13 610 kg)*	32,550 lb* (13 610 kg)*	24,650 lb* (11 420 kg)*	20,850 lb (9 680 kg)	18,100 lb* (8 350 kg)*	13,250 lb (6 160 kg)	13,950 lb (6 480 kg)	9,250 lb (4 300 kg)	10,300 lb (4 790 kg)	6,750 lb (3 150 kg)	34 ft 1 in (10.40 m)	4,350 lb* (1 980 kg)*	4,350 lb* (1 980 kg)*	
<b>Groundline</b>	9,750 lb* (4 370 kg)*	9,750 lb* (4 370 kg)*	22,450 lb* (9 850 kg)*	22,450 lb* (9 850 kg)*	28,250 lb* (13 070 kg)*	19,500 lb (9 060 kg)	19,400 lb* (9 020 kg)	12,550 lb (5 820 kg)	13,500 lb (6 290 kg)	8,850 lb (4 110 kg)	10,050 lb (4 680 kg)	6,550 lb (3 050 kg)	33 ft 4 in (10.16 m)	4,750 lb* (2 160 kg)*	4,750 lb* (2 160 kg)*	
<b>-5 ft (-1.5 m)</b>	17,000 lb* (7 750 kg)*	17,000 lb* (7 750 kg)*	25,950 lb* (11 470 kg)*	25,950 lb* (11 470 kg)*	29,500 lb* (13 630 kg)*	18,850 lb (8 760 kg)	18,900 lb (8 790 kg)	12,100 lb (5 620 kg)	13,200 lb (6 150 kg)	8,550 lb (3 990 kg)	9,950 lb (4 620 kg)	6,450 lb (2 990 kg)	31 ft 9 in (9.68 m)	5,450 lb* (2 470 kg)*	5,450 lb* (2 470 kg)*	
<b>-10 ft (-3 m)</b>	22,250 lb* (9 980 kg)*	22,250 lb* (9 980 kg)*	33,300 lb* (14 720 kg)*	33,300 lb* (14 720 kg)*	29,100 lb* (13 450 kg)*	18,850 lb (8 780 kg)	18,800 lb (8 760 kg)	12,050 lb (5 600 kg)	13,250 lb (6 150 kg)	8,600 lb (4 000 kg)			29 ft 3 in (8.94 m)	6,600 lb* (2 980 kg)*	6,600 lb* (2 980 kg)*	
<b>-15 ft (-4.5 m)</b>	32,900 lb* (14 560 kg)*	32,900 lb* (14 560 kg)*	39,800 lb* (18 450 kg)*	38,550 lb (17 980 kg)*	27,000 lb* (12 510 kg)*	19,250 lb (8 940 kg)	18,950 lb (8 820 kg)	12,400 lb (5 740 kg)	12,700 lb* (6 250 kg)	8,900 lb (4 150 kg)			25 ft 7 in (7.86 m)	8,900 lb* (3 950 kg)*	8,450 lb (3 790 kg)	
<b>-20 ft (-6 m)</b>			30,950 lb* (14 570 kg)*	30,950 lb* (14 570 kg)*	21,250 lb* (10 050 kg)*	19,650 lb (9 140 kg)	13,850 lb* (6 820 kg)*	12,700 lb (5 920 kg)					20 ft 3 in (6.3 m)	13,200 lb* (5 970 kg)*	12,400 lb (5 450 kg)	

NOTE: \*Following number indicates hydraulic capacity.

## STANDARD EQUIPMENT

### ENGINE

Isuzu AQ-4HK1X  
Tier 4 Final Certified  
Selective Catalytic Reduction – SCR  
Diesel Oxidation Catalyst – DOC  
Cooled Exhaust Gas Recirculation – CEGR  
EGR Coolers  
Four-cylinder turbo-charged diesel  
VGT turbocharger  
Electronic fuel injection  
High pressure common rail system  
Neutral safety start  
Auto-engine warm up  
Glow-plug pre-heat  
Fuel Economy Assist System – FEA  
Engine Protection Feature – EPF  
Dual-stage fuel filtration  
Dual element air filter  
Remote oil filter  
Drain for fuel tank  
Remote engine oil drain  
500-hour engine oil change interval  
24 Volt system  
Engine oil sample port  
Battery disconnect switch  
Emergency engine stop  
External Fuel and DEF gauges  
Fan housing  
Fuel cooler  
Fuel filter restriction indicator  
Fuel shut-off valve  
Idle start  
Radiator, oil cooler, intercooler – protective screen

### FUEL ECONOMY SYSTEMS

Engine Idle/Fuel Economy System:  
Auto-idle  
One-touch idle  
Auto-idle shut-down  
BEC – Boom Economy Control  
AEC – Auto Economy Control  
SWC – Swing Relief Control  
SSC – Spool Stroke Control

### HYDRAULICS

Auto power boost  
Auto swing priority  
Arm speed assistance – 2 pump flow  
Auxiliary flow control  
Auxiliary valve  
Boom speed assistance – 2 pump flow  
Bucket curl assist  
Control levers pre-wired for auxiliary hydraulics  
Electronically controlled hydraulic pumps  
Holding valve – Boom and Arm  
Fire wall  
Hydraulic filter restriction indicator  
Neutral pump de-stroke  
Oil cooler

### HYDRAULICS (continued)

Power save  
Pump stand-by pressure  
Auto travel speed change  
Selectable work modes  
Free swing  
Hydraulic oil sample port  
Control pattern selector  
Pre-set auxiliary pump settings  
Auxiliary valve  
5,000-hour hydraulic oil change interval  
1,000-hour hydraulic filter change interval  
SAHR brake

### UPPER STRUCTURE

ISO mirrors – 3  
Cab ISO-Mounts – fluid and spring  
Upper mounted work light – 70 watt  
Swivel guard belly pan  
Center cover – over main CV  
Fuel tank belly pan  
Handrail – RH access  
ISO guard rails  
Lifting eyes for counterweight  
Lockable fuel cap, service doors and tool box

### ATTACHMENTS

Boom – 19 ft 2 in (5.85 m)  
Arm – 9 ft 10 in (3.00 m)  
Heavy-duty bucket linkage  
Boom mounted work light – 70 watt  
Auxiliary pipe brackets  
Centralized grease fittings  
Attachment cushion valve  
Arm and boom regeneration  
Bucket anti-clatter device  
Chrome pins  
Easy Maintenance System (EMS) bushings  
Teardrop pin retention keepers

### OPERATOR ENVIRONMENT

ROPS protection  
FOPS cab top guard – Level 1  
Pressurized cab  
Face vent  
Cab lights – 2  
Interior dome light  
One-touch lock front window  
One piece window – right  
Safety glass windows  
Gate lock hydraulic activation  
Emergency exit and hammer  
Clear polycarbonate roof window with sunshade  
AC/heat/defrost with auto climate control  
LED Color monitor – 7 in (180 mm)  
26 selectable languages for monitor  
On-board diagnostic system

### OPERATOR ENVIRONMENT (continued)

10 programmable attachments settings on monitor – 5 single flow, 5 dual flow  
Seat belt – 3 in (76 mm)  
Heated high-back cloth seat with air suspension and 65° tilt adjustment  
Sliding seat – 3.54 in (90 mm)  
Adjustable armrests  
Tilting consoles – 4-position  
Sliding cockpit – 3.15 in (80 mm)  
Low-effort joystick controls  
Controls pre-wired for auxiliary  
Single pedal travel  
Straight travel  
AM/FM radio with antenna, 2 speakers and Bluetooth capabilities  
Aux-in port for personal electronics  
Radio mute switch – joystick  
Rear-view camera  
Anti-theft system – start code system  
Rubber floor mat  
12 Volt electric outlet  
24 Volt cigarette lighter  
Windshield wiper/washer  
Cup holder  
Storage compartments  
Warm/cool storage compartment  
Travel alarm with cancel switch  
Ignition keys  
One key start & lock-up  
Cab filter – external  
Cab handrails  
Operator's manual

### UNDERCARRIAGE

Long undercarriage  
31.5 in (800 mm) steel shoes, triple semi-grouser  
Full overlap turntable bearing tub  
Single track chain guides  
Hydraulic track adjustment  
Sealed link chain  
Steps  
Carbody belly pan – swivel guard  
X-pattern carbody  
Lashing points – tie downs  
Extra Filter Kit:  
Engine oil filter  
Filter wrench  
Fuel filters  
Grease gun  
Green plug oil drain hose for engine oil drain  
Hydraulic return filter  
Pilot circuit hydraulic filter

### TELEMATICS

CASE SiteWatch™ Telematics – includes hardware and a 3-yr Advanced data subscription

## OPTIONAL EQUIPMENT

### ENGINE

Refueling pump  
Air pre-cleaner – Cyclone  
High ambient temperature cooling package

### HYDRAULICS

Auxiliary hydraulics:  
Single acting/joystick activated  
Double acting/joystick activated – thumb  
Multi-function with electronic pressure control/joystick activated with electronic proportional controls  
Secondary low-flow/joystick activated  
Proportional hydraulic controls  
Hose Burst Check Valve – HBCV

### ATTACHMENTS

Heavy-duty arm – 8 ft 4 in (2.50 m)  
Long arm – 11 ft 6 in (3.52 m)  
Quick coupler/Case multi-pin grabber  
Tools:  
Heavy-duty/Extreme-duty/Ditching Buckets;  
Hammers; Thumbs; Compaction plates.  
Load holding control

### UPPER STRUCTURE

Rubber bumper guard – order through Service Parts

### UNDERCARRIAGE

23.6 in (600 mm) steel shoes, triple semi-grouser  
27.6 in (700 mm) steel shoes, triple semi-grouser  
Track guides – triple

### OPERATOR ENVIRONMENT

FOPS cab top guard – Level 2  
Front grill guard – 2 x 2 in (50.8 x 50.8 mm) screen mesh  
Front rock guard – vertical bars  
Two piece/OPG 1  
Front rock guard – vertical bars  
One piece/OPG 2  
Vandal guard (front window) with common key  
Rain deflector – not available with Front guards  
Sun visor  
Side-view camera  
LED Package:  
Includes 1 Side view camera and 6 LED  
Lights – 2 front cab mounted, 2 rear mounted and 1 mounted on each side



NOTE: All specifications are stated in accordance with SAE Standards or Recommended Practices, where applicable.

NOTE: All engines meet current EPA emissions requirements.

IMPORTANT: Case Construction Equipment Inc. reserves the right to change these specifications without notice and without incurring any obligation relating to such change. Case Construction Equipment Inc. does not warrant the safety or reliability of attachments from other manufacturers.

CASE is a trademark registered in the United States and many other countries, owned by or licensed to CNH Industrial N.V., its subsidiaries or affiliates. CNH Industrial Capital is a trademark in the United States and many other countries, owned by or licensed to CNH Industrial N.V., its subsidiaries or affiliates.



[www.casece.com](http://www.casece.com)