



## EFFICIENCY THROUGH VERSATILITY

Designed for the rental market, the SJ519 TH is a true multipurpose telehandler. With the combination of its capabilities and available attachments, the SJ519 TH provides you with a truly versatile machine that delivers all the job site functionality that is expected of a compact telehandler. Whether you need to lift material to height, work as a tool carrier or maneuver in tight spaces, Skyjack's SJ519 TH exceeds the on-site job performance that fleet managers and operators are accustomed to.

**Skyjack Head Office**  
55 Campbell Rd.  
Guelph, ON Canada N1H 1B9

Sales Inquiries: 1-877-755-4387 (1-877-SJLIFTS)  
Main Switchboard: 1-800-265-2738  
Tel: 519-837-0888  
Fax: 519-837-8104  
Email: [skyjack@skyjack.com](mailto:skyjack@skyjack.com)

[www.skyjack.com](http://www.skyjack.com)



## SJ519 TH TELEHANDLER



SKYJACK 2 YEAR GOLD LEAF PROTECTION PROGRAM

This brochure is for illustrative purpose only and based on the latest information at the time of printing. Skyjack Inc. reserves the right to make changes at any time, without notice, to specifications, standard and optional equipment. Consult the Operating Maintenance and Parts Manuals for proper procedures. Work platforms have been tested to comply with ANSI and CSA standards as interpreted by Skyjack, Inc.

NA/ENG/01/2018

**SKYJACK**  
simply reliable

# LITTLE BIG CAB

If the operator's cab on the SJ519 TH looks familiar, don't be confused - it should! Staying consistent with the TH Series when designing Skyjack's new compact telehandler, it was imperative that the term 'compact' would not have an impact on the operator. With a cab door that fully opens, operators can access the cab with ease, increasing total operator space. As a result of class-leading operator space, the SJ519 TH does not require tilt steering as a standard feature, which is a common feature among its category class.

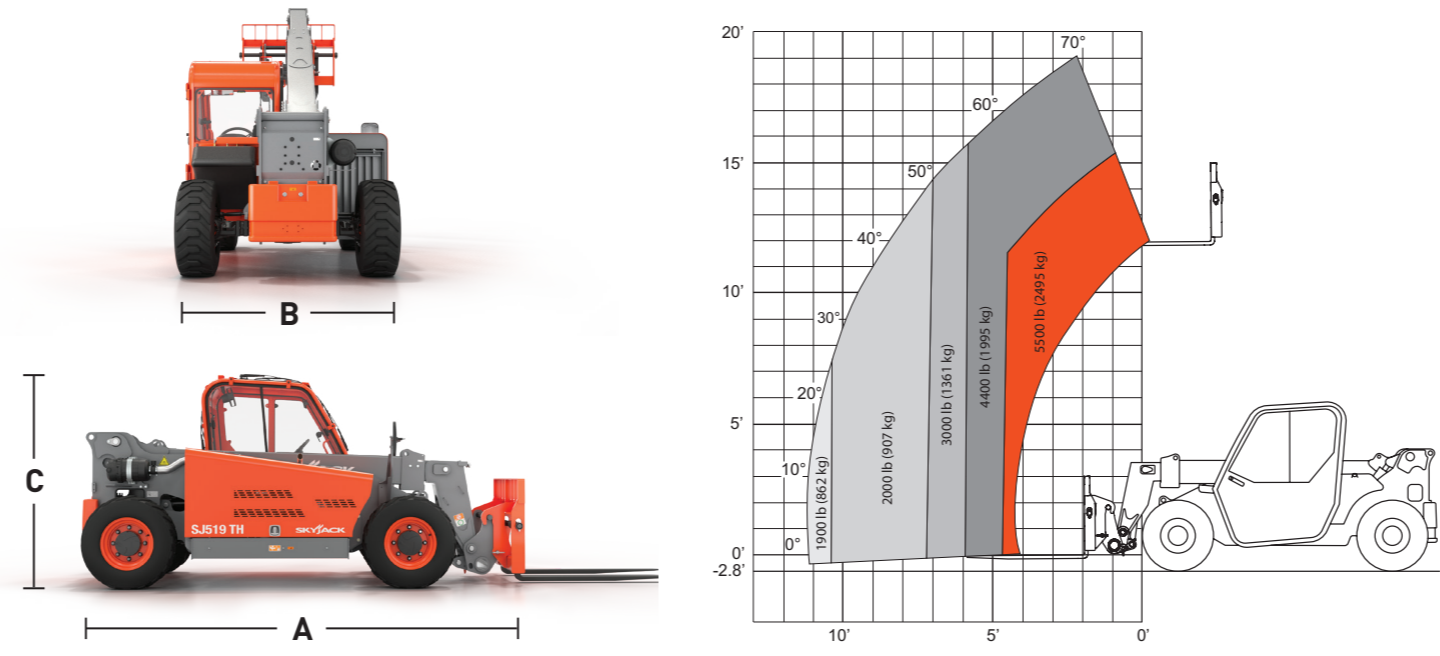

SPECIFICATIONS	SJ519 TH
Maximum Lift Capacity	5,500 lbs (2,500 kg)
Maximum Lift Height	19' 1" (5.82 m)
Rated Lift Capacity @ Maximum Height	4,400 lbs (2,000 kg)
Maximum Forward Reach	11' 2.5" (3.44 m)
Rated Lift Capacity @ Maximum Forward Reach	1,900 lbs (862 kg)
A Length (Stowed - without forks)	13' 0.5" (3.97 m)
B Width	5' 11.5" (1.81 m)
C Height (Stowed)	6' 3" (1.9 m)
Engine	74hp Deutz TCD2.2L T4F
Torque	184 lb-ft
Transmission	Hydrostatic



## FLEXCAB™

- Available conversion kit to convert open cab units to closed cab in less than 2 hours with standard tools
- Bolt on/bolt off flat plane cab glass for easy and economical replacement of broken glass
- Bolt on/bolt off door hinges and drop on door for easy and economical damage repair

## MACHINE OPTIONS

- Closed cab
- Partially enclosed cab
- Road lights
- Work & boom lights
- Back up sensor
- Back up camera & sensor
- Four wheel fender set
- Fire extinguisher bracket
- Rotating beacon
- Cold weather package
- Positive air shut-off valve
- Service convenience package
- Non destructive testing
- Drive speed dial
- Hydraulic carriage connect
- Tilt steering
- 48" Side shift or side tilt
- Pallet forks, 1.5x4x48" or 60"
- 48" Block forks
- 48" Fully tapered forks
- Skid steer attachment
- 6' Truss boom
- 66" Bucket
- Pintle hitch

## TIRE OPTIONS (12X16.5)

- Foam filled tires
- Air filled tires
- Solid rubber
- Non-marking solid
- Non-marking - air filled
- Non-marking - foam filled

## SIMPLE, SERVICEABLE, RELIABLE, SKYJACK.

- Accessible engine bay with full opening steel cowling
- Deutz engine, hydrostatic drive and Dana axles
- Modular cab, easily convert from open to closed in rental yard
- Cast rear counterweight with hitch pin incorporated as standard
- Standard yoke mounted lift shackle and quick attach carriages
- Simple control panel design in-line with TH Series and in-cab engine multifunction display standard

The new SJ519 TH remains consistent with Skyjack's core values of providing easily serviceable and reliable machines. Designed with an oversized engine bay and a fully opening steel cowling, all major service points are easily accessible. Keeping the importance of decreased downtime in mind, the SJ519 TH's parts are easy to access and replace, which provides a leading return on investment for fleet managers. This is all coupled with Skyjack's leading 2-year comprehensive warranty program.



† Capacities, and machine weights may differ when options are added. Preliminary specifications at time of printing. Consult your local area sales representative for details. All Skyjack warranties are subject to express limited warranty and all of other related terms, policies and procedures, as amended from time to time. Please refer to [www.skyjack.com/warranty-service](http://www.skyjack.com/warranty-service)